



BHARAT SANCHAR NIGAM LIMITED

(A Govt. of India Enterprise)

**O/o General Manager Telecom Belgaum
Main Exchange Compound, Camp, Belgaum-590001**

**General Manager Telecom
Belgaum Telecom District.**

**TENDER DOCUMENT FOR
CONSTRUCTION AND
MAINTENANCE WORK OF OPTICAL
FIBRE CABLE AND CONCRETING OF
ROUTE INDICATORS ETC. IN**

Price Rs.1150/-

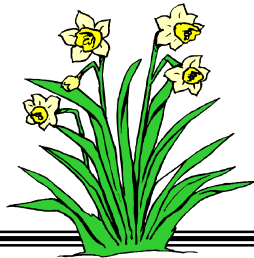

Signature of the Tenderer with Seal

PAGE : 1

BHARAT SANCHAR NIGAM LIMITED
(A Government of India Enterprise)

OFFICE OF THE GENERAL MANAGER TELECOM DISTRICT BELGAUM-590001.

TENDER DETAILS

1. Tender No. : S-13/OFC-MTCE/2009-2010/ 6 dated 04 /09/2009
2. Tender Form No. :
3. Issued to with Address :

4. Time & date of issue of Bid Document : From 09/09/2009 to 23/09/2009 during working hours.
5. Time & Date of depositing Tender/Bid : 1500 Hours of 23/09/2009
6. Time , Date & Venue of Opening of Tender/Bid : 1530 Hours of 23/09/2009
O/o G.M.Telecom Belgaum, Main Tele.Exge.Bldg.Compound,
Belgaum- 590001
7. Cost of Tender Document : Rs.1150/- per copy (Non –Refundable and inclusive of Tax)
8. E.M.D. of the Tender : Rs.1,50,000/-
8. Services to be provided : Construction & Maintenance of O.F. Cable and Concreting of OF Cable Route Indicators etc.
9. Duration of contract : One Year from the date of Award of contract.
10. Initials of the Issuing Officer :

11. For more information log on to www.karnataka.bsnl.co.in

(J.R.NADKARNI)
Asst. General Manager (Planning)
O/O The General Manager Telecom Belgaum,
Main Telephone Exchange Bldg.Compound,
Camp, BELGAUM-590 001.
(Phone No. 0831-2426000)

Signature of the Tenderer with Seal

PAGE : 2

BHARAT SANCHAR NIGAM LIMITED
(A Government of India Enterprise)
OFFICE OF THE GENERAL MANAGER TELECOM BELGAUM,

NO-S-13/OFC-MTCE/2009-2010/ 6 dtd at Belgaum the 04/09/2009.

SECTION – I

TENDER NOTICE

Sealed Tenders in the prescribed proforma are invited by the experienced contractor (As per Section III – 1.b) for and on behalf of the BSNL by the the General Manager Telecom Belgaum for the Work of Construction & Maintenance of O.F. Cable & Concreting OF Cable Route Indicators etc. in Belgaum Telecom District. Approximate Estimated Cost of the work will be Rs. 60,00,000/-.

1.1) Tender documents can be obtained from the Sub-Divisional Engineer (MM), Main Telephone Exge Bldg., Camp, BM-590 001, by producing an account payee crossed Demand draft for Rs.1150/- drawn in favour of the "BSNL BELGAUM T.D." from any of the Scheduled Bank / Nationalised Bank payable at Belgaum. The complete Tender document is available for downloading on the website www.karnataka.bsnl.co.in. ***If you are downloading tender form from website you are requested to enclose separate DD of Rs.1150/- drawn in favour of "BSNL BM TD" Payable at Belgaum, towards cost of the 'Tender document', or otherwise, the tender is liable for rejection.***

1.2) Tenders should be accompanied by the appropriate EMD amount as mentioned in the Tender Document by producing an account payee crossed Demand draft for Rs.1,50,000/- drawn in favour of the "BSNL BELGAUM T.D." from any of the Scheduled Bank / Nationalised Bank payable at Belgaum.). The Tender documents will be issued on all working days during working hours w.e.f. 09/09/2009 upto 23/09/2009. The last date for submission of Tender forms will be 1500 hrs. of 23/09/2009 and will be opened at 1530 hrs. on the same day in the presence of those Tenderers who wish to be present.

1.3) If the last date for submission of tenders and also the tender-opening day happens to be the Holiday by any reason, the tenders will be received / opened on the next working day.

1.4) Three separate Sealed Tender Covers containing the 'Technical Bid', 'Financial Bid' and the cover of DD towards EMD, complete in all respect should be put in a large cover, superscribed on the top of the cover as "TENDER FOR THE WORK OF CONSTRUCTION & MAINTENANCE WORK OF OPTICAL FIBRE CABLE UNDER D.E.TRANSMISSION MTCE.BELGAUM". Details regarding Sealing and Marking the Tender covers are given at Clause No.(6) of Section – III.

1.5. The single (large) cover (containing the above mentioned Three covers) addressed to Smt. J.R.Nadkarni, Asst.General Manager (Plg), O/o the General Manager Telecom Belgaum, Main Telephone Exchange Compound, Camp, Belgaum-590001, should be dropped in the 'Tender-Box' kept in the chamber of the A.G.M.Planning, O/O G.M.T.Belgaum, No tender will be received 'By-hand'. The tenders will be received upto 15.00 hrs. of 23/09/2009. The tenderer may choose to send the Tender by Registered Post/Speed post only, which are receivable upto 1500 hrs of 23/09/2009 No Tenders will be accepted after this time/date. The tenders will be opened at 1530 hrs. on 23/09/2009 in the presence of those Tenderers who wish to be present.

(J.R.NADKARNI)
Asst. General Manager (Planning)
O/O THE GENERAL MANAGER TELECOM BELGAUM-1,
(Phone No. 0831 – 2426000)

Signature of the Tenderer with Seal

PAGE : 3

SECTION II

WORK SPECIFICATION

II.A) WORK SPECIFICATION FOR TRENCHING

1. Trenching work for Construction & Maintenance work or shifting of OF Cable and OF Cable pipeline concreting work etc.

The trenching work involves excavation of the trench upto 1.65 metres depth with minimum of 40 cm width at the top and 30cms width at the bottom on the existing OFC Route or altogether new trench required for OF Cable protection work or for shifting of OF Cable due to widening of the Road etc. The charges for trenching work will be depending on the category of the soil on route as shown below and separate charges as shown at Tender Schedule may be quoted by the Tenderer.

- a. Black/Red soil area trenching and reinstating with soil.
- b. Laterite soil/Hard Murrum soil areas trenching and reinstating with soil.
- c. Hard Rock areas trenching which may require blasting and reinstating the trench with soil.
- d. Hard Rock areas trenching in City /Small Town/village areas where blasting is not permitted and reinstating with soil.

In the Rocky area as above (c)&(d) the trenching is to be carried out not less than one metre depth.

The charges for all types of trenching will be calculated as shown below.

$$\left. \begin{array}{l} \text{Charges per Running Metre of trench as above} \\ \text{Where the trench depth is less than 1.65 M} \end{array} \right\} \frac{Y}{1.65} \times X$$

Where X =the actual average depth in Metres

Y=Rate offered as per Running Metres.

2. The tenderer may offer in the Tender Schedule rates for different types of work as shown below for Construction & Maintenance Work of O.F. Cable.
 - a. Laying the Half Cut HDPE/ PLB pipes over the OF Cable
 - b. Digging the Joint pit of 1.5 Diameter and 1.65metres depth and reinstating with soil.
 - c. Removing/Lowering & Positioning of Joint Chamber set and filling with sand and closing the lid .(Sand charge can be claimed separately)
 - d. Digging of Manhole pits 40cm x 2M x 1.65M (Width x Length x Depth).
 - e. PLB OF Cable pipe laying.
 - f. OF Cable pulling
 - g. GI pipeline laying over HDPE/PLB pipes.
 - h. Shifting of OF Cable along with pipe / Cable.
 - i. Concreting of OF Cable pipe line of 1' x 1' (Thickness x Width) (as shown in the figure below), the cement concrete mixture used should be 1:2:4 composition i.e. , (cement 45 grade,coarse sand & Graded stone) as per the specification / drawing as shown in Figure-I below.The rates should be quoted as per running Metre length inclusive of materials, Labour & Transportation charges of men & material etc,. Separate charges for concreting work will be effected as shown in tender Schedule.

- j. In some areas as required by the Department, the concreting of OF cable pipeline is to be carried out with iron mesh (To be supplied by BSNL) for which separate rate may be quoted for running metre length.
- k. In case of Rocky areas only, where it is difficult to achieve 30cms Width, calculation of concreting work will be done as per the following calculation.
- Charges per Running metre of Concreting in } = $\frac{A \times B}{30 \times 30} \times X$
 Rocky areas
- Where A = Width of Concreting
 B = Height of Concreting
 X = Offered Rate per Running Metre of Concreting.
- No separate charge for trenching will be paid if more than one pipeline is laid in the same trench.
- ❖ In case of shifting of OF Cable the existing OF pipeline should be made free if necessary by breaking/removing existing protection.
- l. Watering of Concrete work (curing) thus completed is to be carried out daily for 5 days continuously ensuring proper curing of the work done.
- m. After Concreting, the OF cable trench should be reinstated by soil properly.
3. Utmost care should be taken while handling of OF Cable & HDPE/PLB pipe .
 4. The work should be done under the guidance & Supervision of the Sub Divisional Engineer or the Junior Telecom Officer of the concerned sections.
 5. Transportation of the Men & Material has to be carried out by the Contractor himself.
 6. Shifting of the OF cable pipe line along with the cable without causing any damage to the cable to new trench.
 7. Jungle cutting or clearing any other obstructions that may be required while shifting the OF cable pipe line along with cable from old trench to the new trench.
 8. Refilling both old and new trenches properly and Replanting /Concreting Route Indicators.
 9. Taking all safety measures while excavating the above work including traffic control
 10. While shifting the existing OF cable with pipe line etc any unforeseen practical difficulties if encountered which involves additional work and labours prior approval should be taken from DE concerned and after his explicit approval for additional expenditures, then only work should be taken up and completed.

SPECIFICATION FOR CONCRETING OF OF CABLE TRENCH

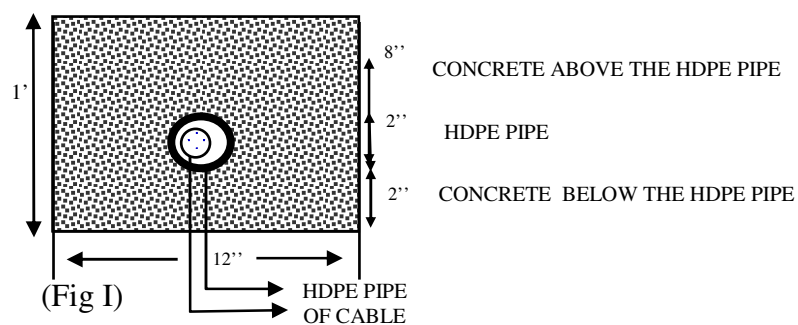

II.B)**WORK SPECIFICATION FOR CONCRETING MANHOLE INDICATOR /****JOINT INDICATOR ON OFC ROUTE. :-**

1. The work involves :-
 - a. Digging of pits of size 9" depth x 12" width x 12" length around the Manhole Indicators of size 6" x 4" x 30".
 - b. Digging of pits of size 9" depth x 12" width x 18" length around joint Indicators of size 12" x 3" x 30".
2. After excavating as above filling with concrete of specifications 1:2:4 i.e., 1 Cement (50 grade), 2 coarse sand & 4 Graded stone 3/4" size around the manhole. Joint Indicators as per specification enclosed in the Drawing at Annexure I (Concreting 3" above the ground & for 9" depth around Manhole / Joint Indicators for 12"L x 12"B & 18"L x 9"B respectively) ensuring 3" concrete around the route/ joint indicators irrespective of the size of the indicators.
3. Concrete provided 3" above the ground around manhole/joint indicators is to be smooth finished (Gilava).
4. Watering of concrete work thus completed, is to be carried out daily for 5 days continuously ensuring proper curing of the work done.
5. Reinstatement of the soil after 5 days around the indicators is to be carried out after proper curing the concreting work.
6. In a few cases where the manhole/joint indicators are placed away from the road (e.g. planted in the field) they may have to be shifted to the road side, as per instruction from Sub-Divisional Engineer/JTO concerned and concreting work is to be carried out after shifting the indicator. Where the manhole/ joint indicators are missing, new indicators are to be planted supplied by the Dept and the concreting work is to be carried out after replanting the indicators as per guidance from concerned SDE/JTO.
7. The concreting work thus completed should be to the full satisfaction of concerned SDE/JTO and any minor modification/changes should be carried out immediately.
8. The rate quoted should be for the Planting/concreting of one route manhole/joint indicator inclusive of materials/Labour and transportation charges of men and material.
9. The Indicators have to be collected from the concerned Sub-Divisional Engineers. Responsibility of safe & storage of the Indicators lie with the contractor.

II.C) Testing and Acceptance Testing :

- i) The work shall be deemed to have been completed only after the same has been accepted by the A.T officer. The contractor shall make test pits at the locations desired by A.T Officer preferably for every 500 meters in open area & 200 meters in city area & minimum One test pit for piece work, for conducting test checks without any extra payment. The Contractor shall restore the pits after test measurements to its original shape. The contractor shall be responsible to provide test/measurement tools and testers for conducting various tests.

- ii) **Scope of Acceptance and Testing:** The purpose of acceptance and Testing is to verify integrity of measurement and quality of work done. The A.T Officer shall not be responsible for recording of measurements for the purpose of billing and contractual obligations. However, if the measurements taken by A.T Officer are found to be lesser than the measurements recorded by the Officer responsible for recording the measurements, the measurement taken by A.T Officer shall prevail without prejudice to any punitive action against the contractor as per provisions of the contract and the officer recording the measurements. The contractor shall be obligated to remove defects/ deficiencies pointed out by A.T Officer without any additional cost to the Corporation.
- iii) **Offering the work for acceptance and testing:** The Sub Divisional Engineer responsible for construction, after having satisfied himself of completion of work ready for A.T, shall offer the work to A.T Officer for conducting Acceptance Testing. The work shall be offered for A.T as soon as part of work is complete in all respects. The work against any work order can be offered for A.T in a number of stages. The concerned A/T Certificate should be enclosed to the respective Bill to be submitted for payment
- iv) The contractor shall provide labour, if demanded by the A.T Officer for digging of test pits and other necessary infrastructure for carrying out the A/T work. No extra payment will be made for the digging of test pit.

(J.R.NADKARNI)
Asst. General Manager (Plg),
O/O G.M.Telecom Belgaum-1.
(Phone No.0831-2426000)

Work Specification Continued.....

Annexure I
DIAGRAM SHOWING DETAILS OF CONCRETING
MANHOLE & JOINT INDICATORS
WITH SPECIFICATION

 PORTION TO BE CONCRETED

SIDE VIEW

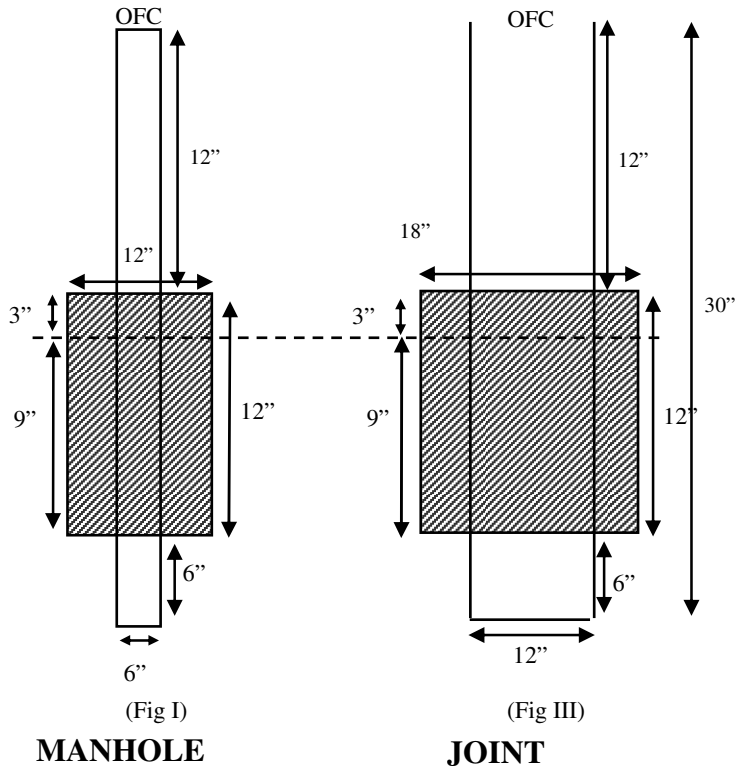

TOP VIEW

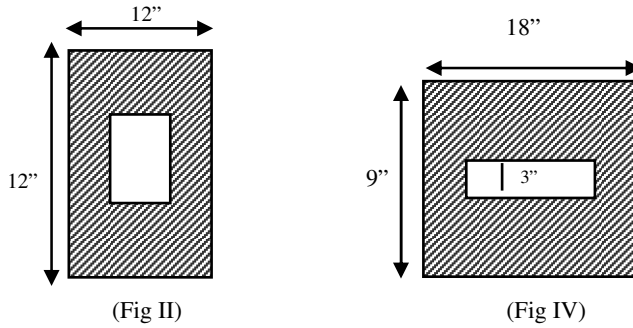

- 1.
- 2.
- 3.
- 4.
- 5.
- 6.
- 7.
- 8.
- 9.
- 10.
- 11.
- 12.

SECTION III

INSTRUCTIONS TO BIDDERS

1. Eligible Bidders & Documents required :

- a) Bidder should be a licensed Contractor Registered with the Central/ State Govt/BSNL/ PSUs. .
- b) The Bidder shall have experience of 25 Kms of O.F.Cable work including digging & reinstating work
And also O.F.Cable Laying & Maintenance work.
- c) The Tenderer should submit along with Tender Form the following Documents
 - i) The Bidder shall furnish the particulars of past performance with supporting 'Experience Certificate' issued by an officer not below the rank of D.E. (of BSNL/PWD/Any other PSU / State Govt.Dept./Central Govt.Dept.), regarding the experience of O.F.Cable work including digging & reinstating work as per (b) above.
 - ii) Partnership deed / Proprietorship deed / Articles of Memorandum of association as the case may be.
 - iii) Copy of Latest Income Tax Certificate(ITCC) along with copy of PAN Card
 - iv) Copy of Service Tax Registration Certificate.
 - v) Copy of Valid and authenticated registration certificate from Govt. of India / Karnataka State Government /BSNL/ PSUs as a 'Licenced Contractor'.
 - v) Bid security (EMD).
 - vi) Bid Form and Price Schedule completed which is given at Section VI & VII..
 - vii) The Tenderer(s) should give a certificate to the effect that none of his\her such relative is working in the units of BSNL as defined above. In case of proprietorship firm the certificate will be given by the proprietor, for partnership firm by all the partners and in case of Limited company by all Directors of the Company.

2. Clarification on Bid document, if any

The Bidder is requested to examine all Instruction forms, Terms and Specification in the Bid documents. Failure to furnish all the information required as per Bid Documents on submission of the Bids not substantially responsive to the Bid Documents in every respect will be at the Bidder's risk and may result in rejection of the Bid. A prospective Bidder requiring any clarification on the Bid document shall notify the AGM(Plg), O/O BSNL Belgaum in writing. The AGM (Plg) shall respond in writing to any request for the clarification of Bid document which it receives not later than 3 days prior to the date of opening of Tender.

3.Bid Form

The Bidder shall complete the Bid form(Section VII) and the appropriate Price Schedule (Section VI)furnished in the Bid document covering the works to be carried out.

4.Bid Price / Rates :

- i) The Contractor shall quote all inclusive but exclusive of 'Service tax', as per Price Schedule given in section VI for all types of works given. The Term ' All inclusive' means inclusive of all the applicable charges and all other taxes except 'Service tax'.

Signature of the Tenderer with Seal

PAGE : 9

ii) The price quoted by the Bidder shall remain fixed during entire period of Contract & shall not be subject to variation on any account. A Bid submitted with an adjustable Price quotation will be treated as non-responsive and rejected.

iii) "Discount" or Extra charges if any mentioned by the Bidders shall not be considered.

iv) BSNL will supply

a) PLB pipes of length 200m to 1000m or smaller, along with sockets

b) GI pipes in lengths of approx 6 meter

c) CI pipes in lengths of approx 5 meter

d) RCC pipes in lengths of 2M with collars; Full-round pipes & Half-round (split) pipes, pre-cast RCC chambers with covers, Joint/Route indicator, Jointing kit.
(Materials required for sealing the couplings / ends will be arranged by the contractor.)

e) G.I. / RCC troughs (Half round pipes/ slabs), Cuddapah/ Napah/ RCC slabs.

f) O.F.Cable.

g) All materials shall be collected by the contractor from the Divisional Store Godown or any other location in the jurisdiction of the Division. No separate charges for loading, unloading, transportation etc., shall be paid by BSNL.

5. Bid Security (EMD)

i) The Bidder must enclose (towards EMD amount) a DD for Rs 1,50,000/- drawn in favour of "BSNL BELGAUM T.D." from any Scheduled/Nationalised bank payable at Belgaum.

ii) The EMD/Bid Security of the successful Bidder will be converted into the "Performance Security Deposit" after award of the tender.

iii) The Bid security of unsuccessful Bidder will be refunded after finalisation of tender.

iv) The Bid Security may be forfeited:

a) If Bidder withdraws his Bid after opening of the tender.

b) If the successful Bidder fails.

i. to sign the Agreement of Contract in accordance with clause 10.

ii. to furnish Security Deposit in accordance with clause 11.

6. SUBMISSION OF TENDERS/BIDS:

6.1 : SEALING AND MARKING OF TENDERS/BIDS:- The tender bid consists of the following documents:

(a) Envelope A- Demand Draft towards EMD .

(b) Envelope B- Techno-commercial Bid in accordance with Clause No.3.

(c) Envelope C - Financial Bid completed in accordance with Clause No.4

6.2 : All the 3 envelopes A, B and C are to be sealed in separate covers superscribing the covers as "Bid security" for Envelop A, "Unpriced Technical bid" for Envelop B and "Financial bid" for Envelop C each cover should have the with bidders seal and tender number. All the 3 envelopes shall be submitted in One big cover suitably sealed and superscribed with "TENDER FOR THE WORK OF CONSTRUCTION & MAINTENANCE OF OPTICAL FIBRE CABLE IN BELGAUM TELECOM DISTRICT" addressed to Smt. J.R.Nadkarni Asst. General Manager (Plg), O/o GMTD Belgaum, Main Telephone Exchange Compound,

Camp, Belgaum-590001, so as to reach him on or before 15.00 hrs of the scheduled date of submission given above.

6.3 :- Only Envelops A and B containing the Bid security (EMD) and Technical bids will be opened on the date mentioned in the Tender notice. Envelop C i.e. the Price bids will be opened only in respect of the bidders who qualify in the technical and commercial bid. The Date of opening of the price bid will be intimated to the eligible bidders subsequently. Corresponding price bids of the ineligible and non-responsive bids will not be opened and same will be returned to the unsuccessful bidder in due course by post or by hand.

6.4 :- Technical Bid :- The Technical Bid shall consist of the following :

- (i) : Documentary evidence established in accordance with the Eligibility Clause No.1 of Section – III, that the bidder is eligible to bid and is qualified to perform the contract if his bid is accepted.
- (ii) Original Tender Document duly signed in all pages by authorised signatory

6.5. Financial Bid :- The Bidder shall complete the Financial Bid and the appropriate Tender Schedule furnished in the 'Section - VI' & the 'Bid Form' given at Section - VII. The rates quoted shall be inclusive of all applicable charges, and all taxes but exclusive of Service Tax. in the enclosed 'Annexure-II. It may please be noted that, 'Service tax' should be shown separately in the 'Financial Bid'. The rates should be quoted clearly both in figures and words, where there is a difference, the rate quoted in words will be final.

7. Any Bid received after the dead line for submission of Bids shall be rejected and returned to the Bidder. Mandatory documents & required documents are to be specified in Tender documents along with the Bids. Non submission of documents along with the Bids are liable for outright rejection.

8. Evaluation

- i. BSNL shall evaluate the Bids to determine whether they are complete, whether any computational errors have been made whether documents have been properly signed and whether Bids are generally in order.
- ii. If there is a discrepancy between words and figures the amount in words shall prevail. Prior to detailed evaluation, BSNL will determine the substantial responsiveness of each Bid to the Bid document. A substantially responsive Bid is one, which confirms to all the terms and conditions of Bid documents without material deviation. A Bid determined as substantially non-responsive will be rejected by BSNL.
- iii. BSNL shall evaluate in detail and compare the substantially responsive Bids and comparison of Bids shall be on the price of the services offered inclusive of all levies and charges as indicated in the price schedule in section VI of the Bid document.
- iv. The quantity indicated in the "Tender Schedule" shall be multiplied with the (All Inclusive) rate (exclusive of 'Service tax'), quoted by the tenderer for each item and the total amount together of all the items mentioned in the "Tender Schedule" shall be compared to arrive at the lowest tender.

9. Right to allotment of work.

In the exigencies of the interest of the BSNL the G.M. Telecom Belgaum, reserves the right to award any of the listed works to any other party at the approved rates other than the approved Tenderer without getting his consent.

10. Signing of Contract

- i. The successful bidder is required to sign an Agreement of Contract (Format given at Section – X) within a week from the receipt of the Provisional Acceptance letter, failing which, the award of tender will be treated as cancelled and the Bid Security of the tenderer will be forfeited to BSNL. . Signing of Agreement shall constitute the award of contract on the Bidder.

11. Security Deposit

- i. The EMD of the successful tenderer will be converted into the Security Deposit after award of tender. In addition to this converted security deposit, the successful Bidder shall be required to deposit an amount of Rs.1,50,000/- as Security Deposit in the form of DD drawn in favour of “BSNL BELGAUM T.D.” from any Scheduled Bank / Nationalised bank payable at Belgaum, within One week of conveying BSNL’s intention for accepting the bid (provisional acceptance letter) or the security deposit for equal amount can be submitted in the form of a Demand Draft drawn in favour of “BSNL BELGAUM T.D.” from any Scheduled Bank/nationalised Bank payable at Belgaum. In this way the total Security deposit of the successful tenderer will be Rs.3,00,000/-. This Security Deposit will be discharged after completion of contractor’s performance & obligations under the contract, after observing all the departmental formalities such as “Satisfactory Completion report” from the Divisional Engineer concerned.
- ii. If the contractor fails or neglects any of his contractual obligations under the contract it shall be lawful for BSNL to forfeit either whole or any part of Security Deposit furnished by the Bidder as compensation for any loss resulting from such failure.

12. **No appeal** against the Any ‘Terms & Conditions’/ Decision of the Competent Authority will be entertained on the matters covered or not covered in the tenders.

13. .Amendment :- In case of ‘Amendment’ if any, the same will be published on the website : www.karnataka.bsnl.co.in, and the same will be binding on the tenderer/tender conditions. It is the responsibility of the tenderer to check the website before submitting his tender.

(J.R.NADKARNI)
Asst. General Manager (PIg),
O/O G.M.Telecom Belgaum-1.
(Phone No.0831-2426000)

SECTION IV

GENERAL (COMMERCIAL) CONDITIONS OF CONTRACT

1. Application

Submission of Bid against this offer shall bind the Bidder for the acceptance of all the conditions specified herein or in NIT unless otherwise agreed by BSNL.

2. PAYMENT TERMS :- The Bills presented by the contractor shall be paid up to a maximum of 90% of bills presented, after certification of satisfactory execution of work, after deduction of the taxes as applicable. The balance 10% of the bill will be retained with the BSNL towards Performance Security Deposit and the same shall be paid after three months of the satisfactory completion of the work in full of the concerned Work Order on production of the 'Satisfactory Completion Certificate' in r/o the concerned work order. The Bills shall be prepared & submitted as per the following guidelines

- i The bills shall be submitted in triplicate to the concerned S.D.E.(Officer In-charge of the Work) as per clause 11 & 12 of **Section V**.
- ii 'Service Tax' should be shown separately in the Bill, or otherwise the Bill shall be rejected.
- iii The bill should be in printed form and serially machine-numbered.
Hand-written Bill will not be accepted.
- iii. The E.P.F. Registration number should be given on the First Bill for payment. The details of the recoveries made towards EPF in r/o each of the labour engaged along with a copy of the receipt (of the amount paid to the concerned EPF Authorities) of the previous month should be enclosed to the Bill of the succeeding month. The details/receipt of the last month of the contract (if any) should be produced before refund of the Security Deposit after expiry of the tender-contract.

3.Termination of Contract

3.1 BSNL may without prejudice to any other remedy for breach of contract may terminate the contract in whole or in parts and forfeit the EMD/SD of the contractor. The competent authority reserves the RIGHT TO TERMINATE CONTRACT within SEVEN DAYS notice

- i) For unsatisfactory/bad work or abnormal delay in completing the work.
- ii) If the contractor fails to perform any other obligation (s) under the contract.

3.2 BSNL may without prejudice to other rights under law or the contract provided get the work done at the risk and cost of the contractor, in above circumstances and the cost of such work got done by the another contractor will be deducted from the bill of the first contractor.

4.Termination for insolvency

BSNL may also by giving written notice and without compensation to the contractor terminate the contract if the contractor becomes unwilling, bankrupt or otherwise insolvent without affecting its right of action or remedy as hirer.

5. Force Majeure

If any time, during the continuance of this contract, the performance in whole or in part by either party of any obligation under this contract is prevented or delayed by reason of any war, or hostility, acts of

public enemy, civil commotion, sabotage, fires, floods, explosions, epidemics, quarantine restrictions, strikes, lockouts or act of God (Hereinafter referred to as events) provided notice of happenings, of any such eventuality is given by either party to the other within 21 days from the date of occurrence thereof, neither party shall be reason of such events be entitled to terminate this contract nor shall either party have any claim for damages against the other in respect of such on performance or delay in performance under the contract shall be resumed as soon as practicable after such an event may come to an end or cease to exit and the decision of BSNL as to whether the supplies have been so resumed or not shall be final and conclusive, provided further that if the performance in whole or part of any obligation under this contract is prevented or delayed by reason of any such event for a period exceeding 60 days either party may, at his option terminate the contract.

6. Arbitration

- 6.1 In the event of any question, dispute or difference arising under the agreement or in connection there with (except as to matter the decision to which is specifically provided under this agreement), the same shall be referred to sole arbitration of the C.G.M.Telecom, Karnataka Circle, Bangalore-8, or any officer appointed by him. If the C.G.M.T. Bangalore or the said officer is unable or unwilling to act as such, than to the sole arbitration of some other person appointed by the CGM/PGM/TDM or the said officer. The agreement to appoint an arbitrator will be in accordance with the Arbitration and Conciliation Act, 1996.
- 6.2 The arbitrator may from time to time with the consent of both the parties enlarge the time frame for making and publishing the award. Subject to aforesaid arbitration and conciliation Act. 1996 and the rules made there under, any modification thereof for the time being in force shall be deemed to apply to arbitration proceeding under this clause.
- 6.3 **Jurisdiction of Court** :- This contract is subject to jurisdiction of Court at Belgaum only.

7. Set Off

Any sum of money due and payable to the contractor (including Security Deposit refundable to him) under this contract may be appropriated by BSNL and set off the same against any claim of BSNL for payment of a sum of money arising out of this contract or under any other contract made by contractor with BSNL..

(J.R.NADKARNI)
Asst. General Manager (Plg),
O/O G.M.Telecom Belgaum-1.
(Phone No.0831-2426000)

SECTION V

SPECIAL CONDITIONS OF CONTRACT

1. BSNL reserves the right to disqualify such Bidders who have a record of not meeting contractual obligations against earlier contract entered into with BSNL.
2. The special conditions of contract shall supplement the instruction to the Bidders as contained in Section III and general (commercial) conditions of the contract as contained in section IV and wherever there is a conflict, the provisions herein shall prevail over those in Section III and Section IV.
3. BSNL reserves the right to blacklist a Bidder for a suitable period in case he fails to honour his Bid and adhere to the contractual obligations.
4. The near relatives of all BSNL employees {Non-executive employees & executive employees} either directly recruited or on deputation are prohibited from participation in this tender. The near relatives for this purpose are defined as:
 - i) Members of a Hindu Undivided Family.
 - ii) They are husband and wife.
 - iii) The one is related to the other in the manner as father, mother, son(s), son's wife (daughter-in-law). Daughter(s) & daughter's husband (son-in-law). Brother(s) & brother's wife. Sister(s) & sister's husband (brother-in-law).
5. The Tenderer(s) should give a certificate to the effect that none of his\her such relative is working in the units of BSNL as defined above. In case of proprietorship firm the certificate will be given by the proprietor, for partnership firm certificate will be given by all the partners and in case of Limited company by all Directors of the Company. Any breach of these conditions by the company or firm or any other person. The Tender work will be cancelled and Earnest Money / Security Deposit will be forfeited at any stage whenever it is noticed. The BSNL will not pay any damages to the company or firm or concerned person. The company or firm or the person will also be debarred for further participation in the concerned unit.
6. **Deduction of Taxes :-** The Tender is governed by Income Tax, Works tax, Service Tax & other Statutory Tax Rules as applicable. The Bills presented will be paid to the contractor after deduction of Income Tax, Works Tax (& any other statutory tax if announced by the Govt. at the time of payment of Bill). Service Tax should be shown separately in the Bill and the same shall be paid to the contractor as per the prevailing rate
7. The Tenderer should clearly quote the rates offered (in words & figures) for all the items of O.F.Cable Construction & Maintenance Works mentioned in the 'Tender Schedule' given at Section – VI., as the tender will be awarded to one party only for all aforesaid works giving primary importance to the work of trenching /concreting. The Tenderer should be ready to carry out all the works mentioned at Sl.No. 1 to 12 in the Tender Schedule given at Section VI, as per requirement of the BSNL Belgaum T.D.

8. The Tenderer before submitting the tender should ensure that the work to be carried out was clearly understood by him by collecting all types of details from the concerned competent authority.
9. The competent authority on behalf of the Bharath Sanchar Nigam Limited reserves the right to accept the Tender in full or part there of or reject any or all the tenders or award work to one or more tenderers without assigning any reasons & the decision of the competent authority shall be final and binding on all concerned.
10. No appeal against the decision of the competent authority will be entertained on the matters covered or not covered in the tenders.
11. **Submission of Bills** :- Pre- receipted bills along with the A/T Certificates in triplicate in the name of the concerned Sub-Divisional Engineer should be submitted within a fortnight's time from the completion of work as and when a portion of the work completed is more than 100 Mtrs of O.F. Cable route length or full length in any particulars section, and in case of concreting work of route indicators work, the bill submitted for the portion of work completed more than 100 route indicators or the full work as per the work order issued if the work is less than 100 indicators.
12. A) The 'Service tax' should be shown separately by the contractor in the Bill. Service tax along with cess will be paid as per the rates in force. The contractor should provide a copy of the 'Service tax registration certificate' and the 'Service tax registration number to claim the service tax. The Service tax Number has to be reflected on all the bills received from the contractor for availing 'Service tax'.
B) 90% of the Bills will be paid after deduction of Income Tax, Works Tax and other statutory taxes, if any (if announced by the Govt. newly), at the prevailing rates. Balance 10% of the Bill shall be retained with the BSNL towards Performance Security Deposit and the same shall be paid after Three months of the completion of the work on production of the 'Satisfactory Completion certificate' from the D.E.Installation Transmission Belgaum.
C) No manpower or conveyance will be provided by the BSNL for execution of the said contract. The successful tenderer has to make his own arrangements for completing the work and no separate charges can be claimed for the same..
13. **VALIDITY** :- Validity of the tender is One Year only from the date of final acceptance of tender.
14. The trenching work will be acceptance tested by the SDE/DE OFC Mtce.Division Belgaum normally. The Tenderer should comply within a week's time the defects noticed during the acceptance testing and if required re offer the work for acceptance testing.
15. After the issue of work order , if due to any reason , the work is not completed within stipulated time period , after issue of warning (reminding) letter, the work order will be cancelled and the in-completed portion of work will be assigned to other approved contractor or completed by BSNL and proportionate expenditure will be deducted from the bill submitted by the contractor.
16. The Tenderer should pay the necessary compensation to BSNL as per departmental procedure for the damage caused to the OF Cable while carrying out the work.

17. NOTIFICATION :- The contractor shall give in writing to the proper person or authority with a copy to the Divisional Engineer such a notification as may be mandatory or necessary in connection with commencement, suspension, resumption, performance and or completion of contractual work.

18. **REFUND OF SECURITY DEPOSIT** :-

- (a) No interest will be payable to the Earnest Money Deposit (Bid Security) or security deposit or amount payable to the contractor under contract. Refund of Security Deposit is subject to the full and final settlement of the final bill for the works contracted/executed under the contract. The Security deposit along with the EMD converted as "Performance Security Deposit" (togetherly Rs. 3,00,000/-) will be refunded after Three months of the successful/satisfactory completion of contractor's performance & obligations under the contract, after observing all the departmental formalities such as "Satisfactory Completion report" from the Divisional Engineer concerned.
- (b) If the contractor fails or neglects any of his obligations under the contract or delays the work beyond the stipulated time-limit, it shall be lawful for BSNL to forfeit the Performance Security Deposit/Security Deposit furnished by the Bidder as per the provisions of the 'Penalty Clause' of this tender..

20. PROTECTION OF THE LIFE AND PROPERTY AND THE EXISTING FACILITIES :

The contractor is fully responsible for taking all possible safety precautions during preparation for and actual performance of work. The contractor should protect all life and property from damage or losses resulting from his operations and shall minimise the disturbance and inconvenience to the public. The contractor shall be solely responsible for locating through approved non destructive means and ensuring the safety of all existing underground pipelines, electrical cables and all other structures. Any damage caused shall be promptly repaired by the contractor without cost to the BSNL.

The contractor is solely responsible for all expences in respect of repairs and or damage occasioned by injury or damage to such existing underground and above structures or other property ,undertake to indemnify and keep indemnified, the BSNL from and against all actions, cause of action, damages, claims, losses and costs (including the cost of litigation), demands whatsoever arising out of or incidental to or in connection with the operation covered by the contractor.

21. **COMPLIANCE WITH LAWS AND REGULATIONS**:- The contractor during the course of performance of a contract, shall comply with all applicable rules, by laws, regulations to any other provision having a force of law made or promulgated or deemed to be made by any Government.

22. **LABOUR REGULATIONS :**

i) The contractor shall at his own responsibility arrange to get necessary license from the Asst. Labour Commissioner (Central) Hubli, required under 'Contract Labour (Regulation and Abolition) Act-1970 and to abide by the provisions of the said act. The contractor shall observe all labour regulations while employing his labourers. No labourer below the age of 18 years shall be employed on the works. The contractor shall be responsible for issuing protective devices like A.C. line tester, rubber handgloves, shoes with rubber soles, safety belts, safety helmets etc., to the labourers working

under him while on work. He should also ensure to take Power shut-downs whenever and wherever necessary with the guidance of the controlling/supervisory officers.

ii) The contractor shall observe all the rules regarding wages to the labours, protection of life, health and sanitary arrangements of the workers employed by him and pay the required compensation to the payable under the Workmen Compensation Act 1923 for injuries or disabilities or death caused in the process of execution of work. In every case in which, by virtue of provisions in the Section 12 subsection (1) on the Workmen's Compensation Act 1923, where the BSNL is obliged to pay compensation to a workman employed by the contractor for execution of the work, the BSNL will recover the amount of compensation so paid from the Security deposit or from any sum due from the BSNL to the contractor, whether under this contract or otherwise. In such cases, the decision of the labour commissioner of the locality will be final and binding.

23. **E.P.F.REGISTRATION** : i) The successful tenderer will have to register his firm with the E.P.F. Authorities immediately after award of Tender, & the E.P.F.Registration number should be produced to the A.G.M.(Planning) O/O GMT BM, before submission of the First Bill for payment. The details of the recoveries made towards EPF in r/o each of the labour engaged along with a copy of the receipt (of the amount paid to the concerned EPF Authorities) of the previous month should be enclosed to the Bill of the succeeding month. The details/receipt of the last month of the contract (if any) should be produced before refund of the Security Deposit after expiry of the tender-contract.

24. **SERVICE TAX REGISTRATION** :- The firm should have the Service Tax Registration Certificate and a copy of the same should be enclosed to the Tender document.

25. **OPTIONAL TERMINATION BY BSNL** :- The BSNL may at any time at his option cancel and terminate this contract by written notice to the contractor, in which event, the contractor shall be entitled to payment for the work done up to the time of such cancellation. In the event of termination of the contract the contractor shall forthwith clear the site of all the contractor's materials, machinery and equipments and handover possession of the work operation concerned to the BSNL. Or as the BSNL may direct.

26) **PENALTY CLAUSE AND BLACK-LISTING**

26.1. **Penalty for Unsatisfactory Work :**

26.1.a) The time allowed for completion of work as entered in the Work Order shall be strictly adhered to by the contractor and shall be deemed to be the most important aspect of the contract on the part of the contractor. If the work is not completed within the time stipulated in the Work Order, such shortfalls fulfilling the above conditions shall be penalised at the rate of 0.25% of the total value of the Work Order per day of delay or part thereof subject to a maximum of 10% of the value of the Work Order. If the work is not completed even after Six weeks of the expiry of the due date, the BSNL has right to cancel the contract and forfeit the EMD / SD.

26.1.b) In case of slow progress of the work in a section which have been awarded to a particular contractor, & the public interest does not permit extension of time limit for completion of the work, the GMT Belgaum will have the full right to order that the scope of the contractor may be restricted to such fraction of

the whole of the work & get the balance executed at the risk & cost of the contractor.. All such payments shall be recovered from the contractor's pending bills or security deposit.

26.1.c) Failure to adhere to any of the contractual obligations, will lead to the Forfeiture of EMD/SD and BLACK-LISTING of the contractor and the Black-listed contractor will not be permitted to submit tenders in Belgaum Telecom District and also his name will be circulated in the entire Karnataka Telecom Circle as a BLACK-LISTED CONTRACTOR.

26.1.d) Decision regarding forfeiture of EMD / SD / Black-listing or Condoning of delay with genuine reasons given by the contractor in writing will be taken by the GM only.

26.2 Penalty for cutting /damaging the old cable:

During excavation of trench utmost care is to be taken by the contractor, so that the existing underground cables are not damaged or cut. In case any damage/cut is done to the existing cables, a penalty as per the schedule given below (irrespective of the number of cuts involved) will be charged from the contractor or the amount will be deducted from his running bills:

Size of existing UG/OF Cables cut/damaged Amount of penalty per cut / damage

Up to 100 pairs cable

Rs.500.00 (Five hundred)

Above 100 pairs & up to 400 pairs

Rs.1,000.00 (One thousand)

Above 400 pairs

Rs.2,000.00(Two thousand)

OF Cable of any size

Rs.5000.00 (Five thousand)

Besides the above penalty, the contractor shall carry out repairs for restoration of the damaged cable free of charge. The cost of jointing kit shall also be borne by the contractor. If contractor fails to repair the damage, the cost of repair (including cost of labour + jointing kit) shall be recovered from the contractor either from his bill or from his Security Deposit, in addition to the above mentioned penalty.

27. TAXES AND DUTIES :-

The Contractor shall pay all rates, levies, fees, royalties, taxes and duties payable or arising out of by virtue of or in connection with and or incidental to the contract or any of the obligations of the parties in terms of the contract documents and or in respect of the works or operations.

(J.R.NADKARNI)
Asst. General Manager (Plg),
O/O G.M.Telecom Belgaum-1.
(Phone No.0831-2426000)

SECTION-VI

TENDER SCHEDULE

TO,
 The Asst.General Manager (Plg-I),
 O/o the G.M.Telecom Belgaum,
 Main Telephone exchange Compound, Camp, Belgaum-590001.

Sir,
 With reference to your Tender Notice S-13/OFC-Mtce/ 2009-2010 / 6 dated 04/09/2009. I/We Tender My/Our rates as follows for the work in Belgaum Transmission Maintenance Division.:-

Sl. No.	NAME OF THE WORK (Work as per the specifications)	QTY.	RATE QUOTED IN RUPEES (All inclusive but exclusive of Service Tax)
1	a) Digging OF Trench in Black /Red soil areas and reinstating with soil. (Rate per running metre)	17500 Mtrs.	Rs..... (In Words.....
	b)Digging OF Trench in Laterite soil /Hard murrum areas and reinstating with soil. (Rate per running metre)	5000 Mtrs.	Rs..... (In Words.....
	c)Digging OF trench in Hard Rock area which may require blasting and re instating with soil. (Rate per running metre)	2500 Mtrs.	Rs..... (In Words.....
2	Laying of Half cut pipes over the PLB / HDPE pipes. (Rate per running metre)	5000 Mtrs.	Rs..... (In Words.....
3	Laying of GI pipe/Round RCC pipe over the PLB /HDPE pipes. (Rate per running metre)	2500 Mtrs.	Rs..... (In Words.....
4	PLB pipeline laying. (Rate per running metre)	19000 Mtrs.	Rs..... (In Words.....
5	OF Cable pulling. (Rate per running metre)	20000 Mtrs.	Rs..... (In Words.....
6	Concreting of O.F. Pipeline with 1:2:4 concrete and 1' x 1' thickness (For protection work of RODENT prone Area, Low depth areas including Hard Rocky areas, Black soil areas etc.)	25000 Mtrs.	Rs..... (In Words.....
	Contreting as above with Iron Mesh (Rate per running meter)		
7	Digging of Joint pit of 1.5M Diameter and 1.65 M depth and reinstating with soil. (Rate per joint pit)	100 Nos.	Rs..... (In Words.....

Signature of the Tenderer with Seal

PAGE : 20

8	Digging of Manhole pit of 40cm(width) x 2M Length x 1.65 M depth and reinstating with soil. (Rate per Man Hole)	100 Nos.	Rs..... (In Words.....
9	Planting/concreting of O.F. Manhole / joint indicator. (Rate per indicator)	250 Nos.	
10	Removing/ Lowering& Positioning of Joint Chambers ,Filling with sand and closing the lid(Sand cost may be claimed separately. (Rate per Joint Chamber)	50 Nos.	Rs..... (In Words.....
11	Shifting of OF Cable along with PLB/HDPE pipe from the existing trench to the new trench. (Rate per running metre length)	1000 mtrs	Rs..... (In Words.....
12	Trenching by Horizontal drilling method (HDD) using suitable appliances for the work of Pipe Laying across Rail/Road-crossings or other places where trenching not possible and inserting 65/40 dia G.I.Pipes and pulling HDPE/PLB pipes/coils inside and drawing 6 mm PP Rope (Rate per meter)	200 mtrs	Rs..... (In Words.....

(S.N. :- (1) The quantity indicated in the "Tender Schedule" shall be multiplied with the rate quoted by the tenderer for each item and the total amount together of all the items mentioned in the "Tender Schedule" shall be compared to arrive at the lowest tender.

(2) The Quantity indicated above is approximate and may vary widely.)

(3) Rates quoted above are inclusive of all, i.e., All taxes, transportation, loading/unloading, insurance and any other charges if applicable) but Exclusive of Service tax. No extra charge Except 'Service Tax' shall be levied over & above the rates quoted above.

We also hereby declare that I/We have gone through all the terms and conditions and specifications mentioned in the Tender document and I/We agree to and abide by the same fully. I/We am/are also aware that my/our EMD Amount will be forfeited in favour of BSNL if I/We fail to comply with any of the Tender conditions mentioned in your Tender document.

EMD paid by Demand Draft No.....dtd..... for Rs...../- is enclosed.

SIGNATURE OF THE TENDERER WITH NAME/SEAL

Signature of Witness :

Name of Witness.

SECTION VII

BID FORM

Tender No .S-13/OFC-MTCE/2009-10/ 6

Dated 04/09/2009.

(Name & Address of the Contractor)

Dear Sir,

Having the conditions of contract and services to be provided ,the receipt of which is hereby duly acknowledge, I/ we, undersigned, offer to provide services in conformity with the conditions of contract and specifications for the sum shown in the schedule of prices attached herewith and made part of this Bid.

I/We undertake, to enter into agreement within one week of being called upon to do so and bear all expenses including charges for stamps etc. and agreement will be binding on us.

If My/Our Bid is accepted, I/ we will deposit a Security Deposit in the form of DD from a Scheduled Bank for a sum as mentioned in the Tender document for the due performance of the Contract.

Until an agreement is signed and executed, this Bid together with your written acceptance there of in your notification of award shall constitute a binding contract between us.

Bid submitted by Me/Us is properly sealed and prepared so as to prevent any subsequent replacement.

I/We understand that you are not bound to accept the lowest or any Bid, you may receive.

Dated thisDay of2009

Signature of

In capacity of

Duly authorized to sign the Bid for and on behalf of

Witness.....

Address.....

Signature

SECTION VIII

c) SERVICES TO BE PROVIDED

1. Service : Construction & maintenance Work of O.F. Cable and Planting/concreting of OF Cable Route Indicators Etc.
2. Period of Contract: Under normal circumstances the contract shall be valid for a period of one year from date of final acceptance of tender.
3. Work Specification and Details of work to be done:As mentioned in SECTION II at any place under jurisdiction of DE TM Belgaum (Belgaum District).
4. Notice period :
 - i) In normal course as per Work Order issued from time to time.
 - ii) Telephonic intimation shall be considered as notice in case of emergencies like Cable Fault or Urgent Shifting /Diversion work Etc. and the work Order will also follow immediately.
5. Reporting Place :Any place within the jurisdiction of DE Transmission Mtce. BM. Actual place of working shall be specified by Route/Work Incharge Officer.
6. Penalties : The Contractor should commence and complete the work within the time stipulated in the Work-order, failing which, the Penalty as per the "Penalty Clause" given above in "SECTION-V" will be imposed and action will be taken accordingly.
7. Special Requirements :
 - i. Intending Bidder must have a telephone / mobile No. and the Telephone / Mobile No. must be specified in the Bid.
 - ii. The Contractor should not be an employee of BSNL.

(J.R.NADKARNI)
Asst. General Manager (Plg),
O/O G.M.Telecom Belgaum-1.
(Phone No.0831-2426000)

SECTION IX
INFORMATION TO BE FURNISHED BY THE TENDERER

1. Name of the Firm/Individual and Registered Address	1.
2. Telephone Number : a) Office : b) Residence : c) Mobile : d) FAX :	
3. Whether it is sole proprietary or partnership Firm / Private Limited Company.	
4. Name of sole Proprietor/Name of Partners /Name of Director(s)	
5. Name of person authorised to enter into and execute contract agreement and the capacity in which he is authorised.	
6. Permanent Income Tax No (PAN NO.)	
7. Service Tax Registration No.	
8. EPF Registration No.	
9. Whether the firm has ever been Black-listed ; if so, give details.	
10. Whether the firm is having branches at more than one place? If so details.	

SIGNATURE OF THE TENDERER WITH NAME/SEAL.

PLACE :
DATE :

Signature of the Tenderer with Seal

PAGE : 24

SECTION X

AGREEMENT FORM

AGREEMENT made this _____ day of _____ Two Thousand between the BHARATH SANCHAR NIGAM LIMITED here in after called the BSNL Which expression shall unless excluded by or repugnant to the context include his successors and assignees on the one part and _____ having its registered office at _____ (acting through its constituted Attorney) herein after called the "Contractor" (Which them shall include their heirs, executors, successors and assignees) on the other part.

WHEREAS THE Bharat Sanchar Nigam Limited is desirous of getting executed certain works namely _____

AND WHEREAS the contractor is ready and willing to execute the said works in accordance with the terms of the agreement.

NOW THIS AGREEMENT WITNESSTH and it is here by declared as follows:

All the Terms and Conditions of the Tender-document No.S-13/OFC-Mtce/09-10/ 2 dtd /07/2009, and the The Tender-Notice instructions to tenderers, conditions of Agreement construction-specifications, guide lines to the Agency, Schedule Letters of Intent No. dated . . (along with its enclosures) annexed here to and such other additional particulars, instructions, drawings as may be found requisite to be given during execution of the work shall be deemed and taken to be an integral part of the contract and shall also be deemed to be included in the expression ``Agreement" or "Documents of Agreement" wherever herein used.

In consideration of the payments to be made to the Agency for the works to be executed by him the agency hereby convenants with the Bharat Sanchar Nigam Limited that the Agency shall in accordance with the agreement documents duly provide execute and complete the said works and shall perform all other acts deeds matters and things in their agreement mentioned or described or which are to be implied there from or may reasonably necessary for the completion of the said works and at the time and in the manner and subject to the terms and conditions of stipulations mentioned in the Agreement.

In consideration of the due provisions executions and completion of the said works Bharat Sanchar Nigam Limited hereby agrees with the Service Agency that the Bharat Sanchar Nigam Limited will pay to agency the respective amounts for the work done by the Agency and such other sum (s) as may become payable to the Agency under the provisions of the Contract.

IN WITNESS where of the parties here to have executed these presents the day month and the year first above written.

Signed on Behalf of the
BSNL Belgaum T.D.(With Seal)

Signed by/on behalf of the
Successful Tenderer.

Signature of witness:

Signature of witness :

Name & Address :

Name & Address :